

LUBRICATION ORDER

LO 5-6115-593-12

17 AUGUST 1987

GENERATOR SET, DIESEL DRIVEN, 500KW, 120/208-240/416V, 3 PHASE, 4 WIRE, 50-60 HERTZ, SKID MOUNTED, (TACTICAL UTILITY) NSN 6115-01-030-6085

Reference: C1900-IL

Intervals are based on normal hours of operation. Adjust to compensate for abnormal operation and severe conditions. During inactive periods sufficient lubrication must be performed for adequate preservation.

Level of maintenance is indicated at Note reference by (c) for Crew/Operator, and (o) for Organizational maintenance. Clean fittings before lubricating. Clean parts with SOLVENT, dry-cleaning, or OIL, fuel diesel. Dry before lubricating.

Drain crankcase when hot. Fill and check level.

LUBRICANT • INTERVAL

INTERVAL • LUBRICANT

Hydraulic Sump
(Check level) (c)
(Fill and drain) (o)
(See Key)

Engine Oil
Drain Plug and
Valve (Drain and
refill) (o)
(See Key)

Motors (2)
Potentiometer-
Motor Operated
(See Note 2) (o)

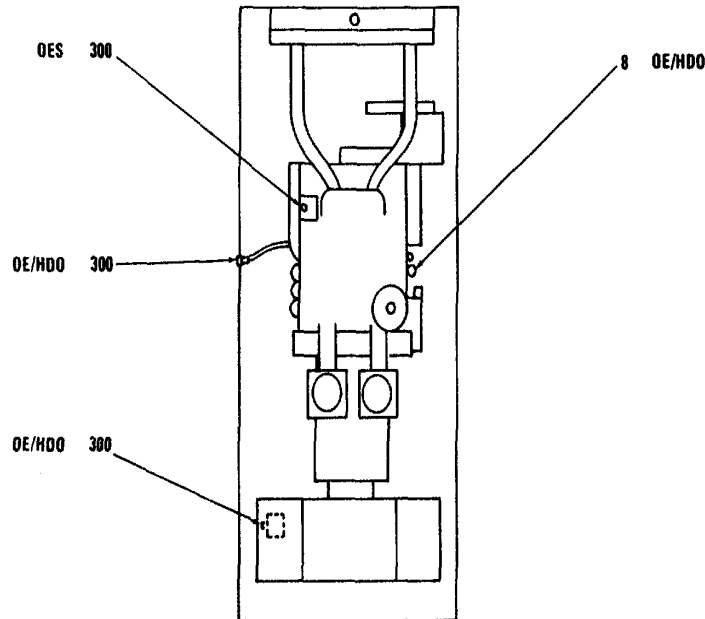

Crankcase
(Check level) (c)
(See Key)

KEY

LUBRICANTS	CAP.	EXPECTED TEMPERATURES			INTERVALS
		ABOVE +32°F (0°C)	+40° to -10°F (4.4° to -23°C)	0 to -25°F (18 to -32°C) (With Housing Kit)	
OE/HDO-LUBRICATING oil MIL-L-2104, internal combustion engine or MIL-L-2104D	18 gal. (68 l)	OE/HDO 30 or OE/HDO 15W-40	OE/HDO 10 or OE/HDO 15W-40	OES	Intervals given are in hours of normal operation.
OES - OIL, engine		All Temperatures			

TS 6115-593-12/3-1(1)

NOTES:

1. FOR OPERATION OF EQUIPMENT BELOW -10°F. (-23°C), remove lubricants prescribed in the Key, and replace with lubricants for temperature below -10°F.(-23°C).
2. OIL CAN POINTS. Every 100 hour lubricate hinges, latches, and all exposed adjusting threads with OE/HDO.

Copy of this Lubrication Order will remain with the equipment at all times; instructions contained herein are mandatory.

By Order of the Secretary of the Army:

CARL E. VUONO
General, United States Army
Chief of Staff

Official:

R. L. DILWORTH
Brigadier General. United States Army
The Adjutant General

DISTRIBUTION:

To be distributed in accordance with DA Form 12-25A, Operator and Unit Maintenance requirements for Generator Set, Diesel Driven, Tactical, 120/208V, 240/416V, 500OKW, 50/60HZ, 3PH, 4 WIRE (MEP-029A)

LO 5-6115-593-12

Card 2 of 2

PIN: 062509 / 000

RECOMMENDED CHANGES TO EQUIPMENT TECHNICAL PUBLICATIONS

 <div style="border: 1px solid black; border-radius: 15px; padding: 5px; display: inline-block; margin-left: 20px;"> <p style="font-size: small; margin: 0;">THEN...JOT DOWN THE DOPE ABOUT IT ON THIS FORM. CAREFULLY TEAR IT OUT, FOLD IT AND DROP IT IN THE MAIL.</p> </div>		SOMETHING WRONG WITH PUBLICATION	
		FROM: (PRINT YOUR UNIT'S COMPLETE ADDRESS)	
		DATE SENT	
PUBLICATION NUMBER		PUBLICATION DATE	PUBLICATION TITLE
IN THIS SPACE, TELL WHAT IS WRONG AND WHAT SHOULD BE DONE ABOUT IT.			
BE EXACT PIN-POINT WHERE IT IS			
PAGE NO.	PARA- GRAPH	FIGURE NO.	TABLE NO.
PRINTED NAME, GRADE OR TITLE AND TELEPHONE NUMBER		SIGN HERE	

